

Active Isolation System AIS™

AIS™
Active Isolation System

Active electronic-pneumatic vibration insulation system with powerful real-time control for the highest demands on effective insulation, deflection and constant level.



- Active electronic-pneumatic vibration insulation with up to 6 controlled degrees of freedom.
- Air springs work as passive air springs and as actuators
- Highly efficient vibration insulation without resonance peaks
- Optimum positional accuracy in the vertical direction and horizontal plane
- Minimum deflection and settling time in response to machine load changes
- Very powerful real-time control
- PLC, CAN bus and one controller and one highly dynamic proportional valve per degree of freedom
- Each controller has a microprocessor and integrated high resolution sensors for position, pressure, and acceleration
- User-friendly, intelligent WinSNI/Web-Visu-Software for commissioning and diagnostics
- Simple digital switching capability between scanning mode (during sensitive machine operations) and loading mode (in response to machine load changes)
- No feed forward signal required
- No disturbing heat generation, magnetic field fluctuations or high power consumption as is the case with electromagnetic actuators



TRANSMISSION FUNCTION AIS™

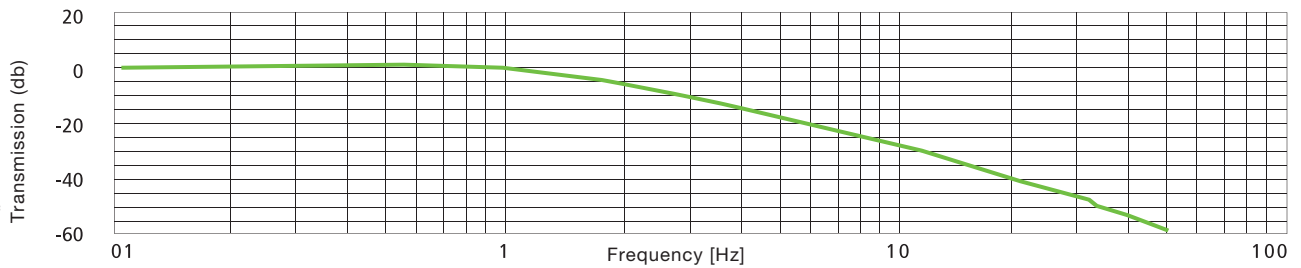

Membrane air spring BiAir®/-ED/HE-MAX



COMPASS PRO Wafer Inspection Machine



Electron microscope on a vibration insulating platform



AIS™ on Bilz measuring and test bed

VIBRATION CRITERIA VC

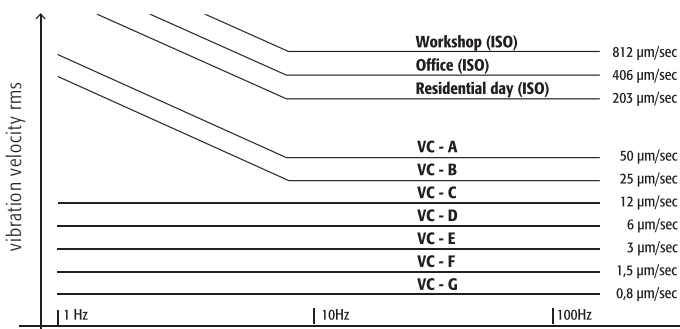

APPLICATION AREA

Optimum vibration insulation system for highly dynamic measuring and testing machines, laser high-resolution microscopes as well as inspection and production machines in the semiconductor industry.

AIS™ is used when the insulation effect and reaction times of conventional passive air spring insulators and a customary level control system are not sufficient.

TASKS

- Protection of vibration-sensitive machinery from floor vibrations.
- Minimization of structure borne vibration within a system. These are caused by load changes or movements of the machine.
- Settling time reduction.

AIS™ enables the highly efficient, vibration insulated installation of highly dynamic machines without loss of performance or cycle time.

Active Isolation System AIS™

The Bilz AIS™ system is comprised of a PLC, CAN bus, 16-bit state controller, highly dynamic proportional valves, the BiAir® membrane air spring and the HAB™ horizontal air spring. A wide range of different sizes of valves and air springs for system design are available.

One controller and one valve are assigned to one air spring or one group of air springs. AIS™ works with at least three controlled groups of air springs and can be used with up to 6 degrees of freedom. The controllers are linked with the PLC via CAN bus.

A PC can be linked via a series RS-232 or Ethernet interface for commissioning and diagnostic purposes. The controller is mechanically coupled with the air spring insulator or to the machine in the direction of the force. Integrated on each controller is a microprocessor, a displacement measuring system for position feedback (resolution 0.2 µm), as well as an accelerometer (resolution 8 µg) and a pressure sensor (resolution 0.2 mbar). The signal sensor sampling rate is 4 kHz. As not only the higher-level control, but also each controller is equipped with a microprocessor and highly dynamic proportional valves



are used, we can consider the system to be a powerful real-time control and an elaborate feed forward control from the machine manufacturer can be omitted.

The PLC also provides digital inputs and outputs, such as ready, pressure monitoring, position and tension, switching between scanning/loading mode, emergency stop. The user friendly switching capability between scanning and loading mode offers the advantage of parameterizing the insulation system for machine load changes so that it achieves the greatest rigidity, fastest response and accurate positioning and during machine operations so that it responds very gently and not aggressively.

SYSTEM DESIGN

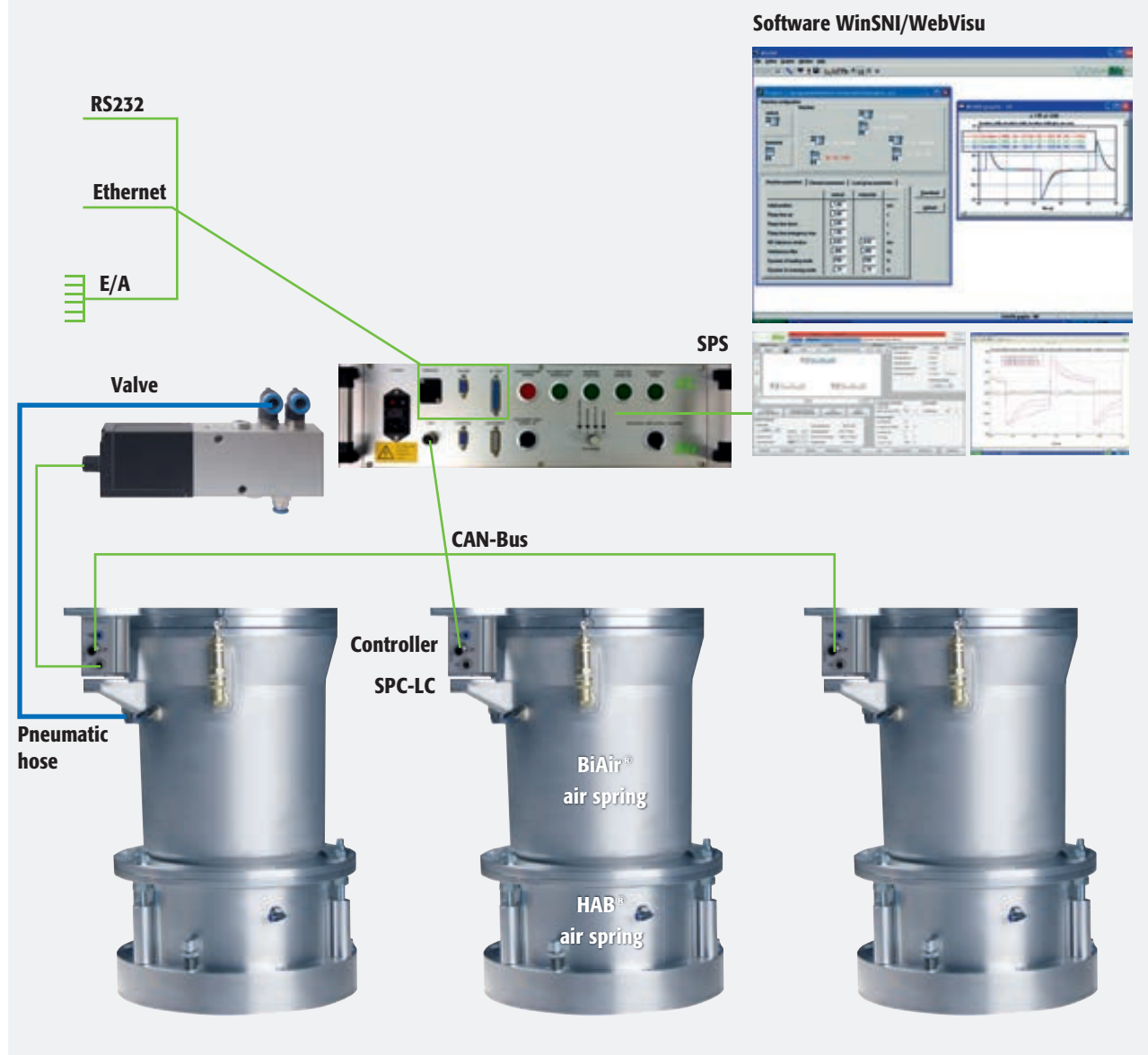

CONTROLLER 19" PLC AND AIR SUPPLY 19" AirBox

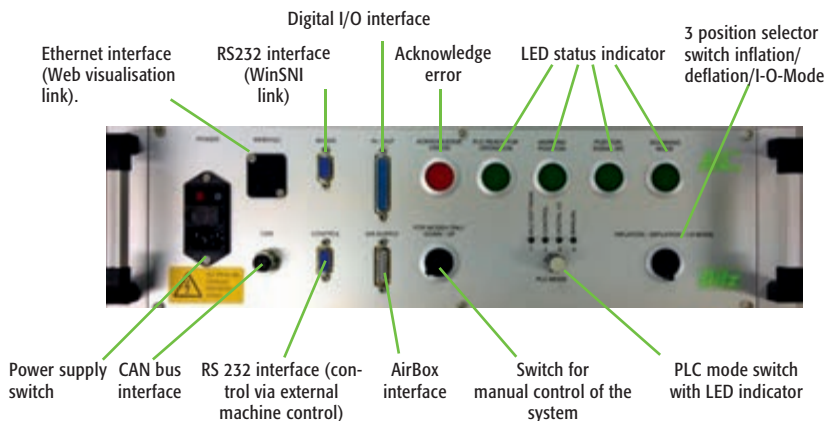

Dimensions: W / H / D / 483 x 133 x 270 mm

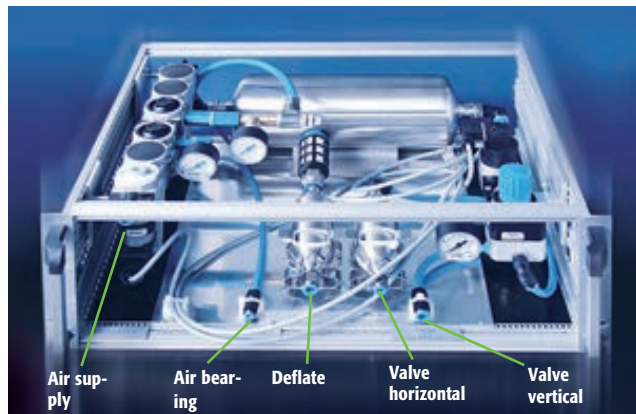

Dimensions: W / H / D / 483 x 177 x 384 mm

CONTROLLER SPC-LC



ARRANGEMENT OF THE AIS™ SYSTEM FOR AIR SPRINGS AND CONTROLLERS WITH 6 DEGREES OF FREEDOM

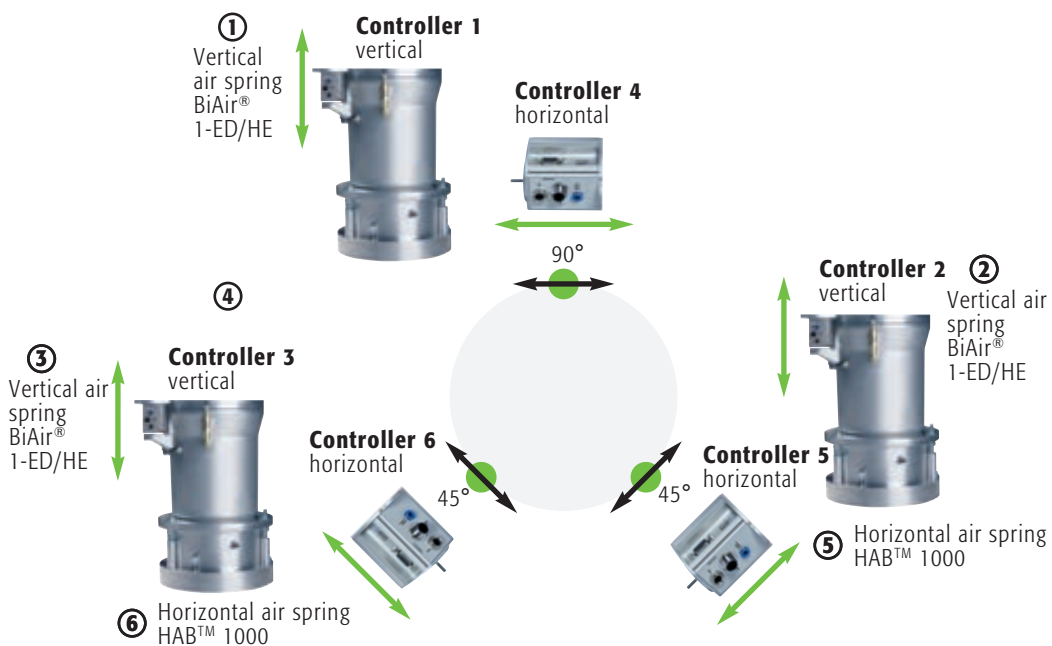

Application example: Electron microscope on a vibration insulating platform

Right to make technical changes is reserved.

HAB™ Horizontal air springs

AIS™
Active Isolation System

Horizontal vibration insulation with
AIS™ systems with 6 degrees of freedom.

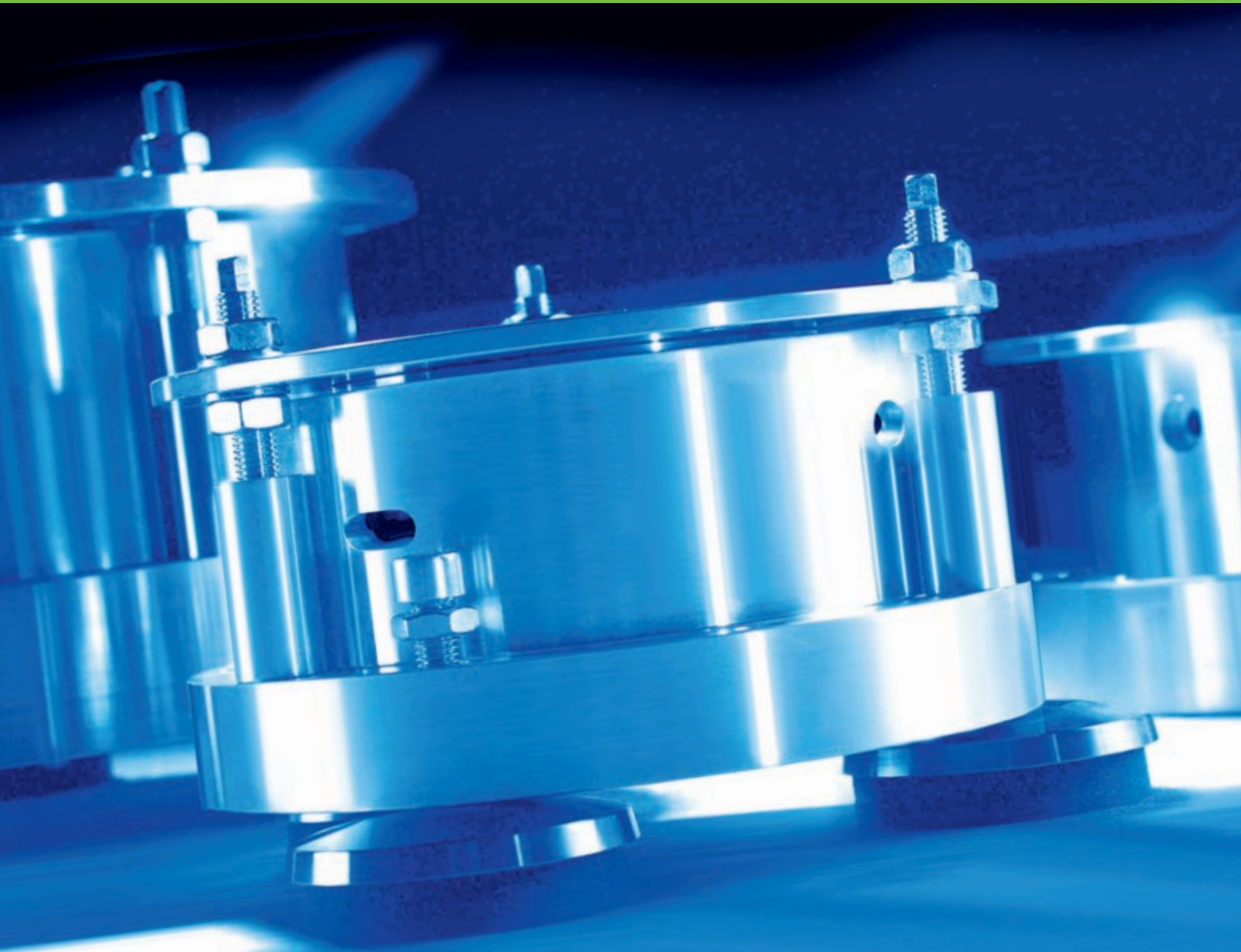

Product description

Pneumatic horizontal vibration insulator each comprising of a cylindrical upper housing section and lower housing section. The two cylindrical side walls form an annular gap into which the air tubes are inserted and which act against the radially directed relative movements between the upper and lower sections. The necessary horizontal force depending on the machine type or the natural frequency of the air hoses can be adjusted using the variable air pressure.

A special air bearing is used to carry the vertical load resting on the upper section and to prevent frictional forces in the horizontal plane

The advantages compared to conventional air spring systems

- Application specific adjustable natural frequency
- Damping in the horizontal plane
- No uncontrolled frictional effects (such as slip-stick effects)
- In combination with AIS™:
 - No resonance peaks
 - Above average damping
 - Minimum settling time
 - High positional accuracy



Patents: German patent no. 102 49 647.1 – German patent no. 102 49 647

HAB™ HORIZONTAL AIR SPRING

Type	Item no.	Ø A mm	Ø B mm	H mm	Levelling bolt	max. vertical load capacity at 5.5 bar N	max. horizontal force absorption at 1 bar N	Adjustable horizontal natural frequency Hz
HAB™ 280	53-0055	200	180	101	M10 x 1.5	3,400	150	1.1 – 1.9
HAB™ 660	53-0084	250	230	118	M10 x 1.5	7,200	380	1.1 – 1.9
HAB™ 1000	53-0023	300	276	159	M12 x 1.5	11,000	490	1.1 – 1.9
HAB™ 1000-HL	53-0025	300	276	159	M12 x 1.5	14,000	490	1.1 – 1.9
HAB™ 24000	53-0039	350	326	172	M16 x 1.5	23,500	700	1.1 – 1.9
HAB™ 38000	53-0069	422	398	187	M16 x 1.5	38,000	1100	1.1 – 1.9

Larger sizes available on request!

Note

- In addition to our standard solutions listed here we also supply numerous special solutions. Please contact us, we would be happy to advise you.

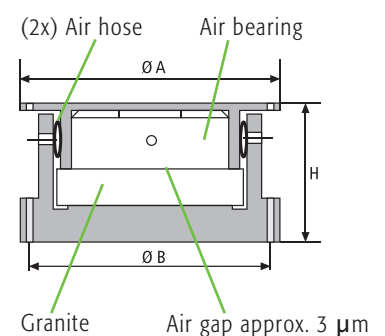

Right to make technical changes is reserved.

Active Isolation System AIS™ High Performance

AIS™
Active Isolation System

Active vibration insulation in 6 degrees of freedom offering the best possible insulation effect



FUNCTION

With an elastic machine mount on vertical air springs (such as Bilz BiAir®-ED) the insulated mass is carried on a volume of air enclosed by a membrane in the interior of the insulator. Because of the elastic properties of this air spring membrane the insulator has free movement in the vertical plane, and also a limited movement in the horizontal plane.

For extremely sensitive and high-precision applications, which must be mounted with 6 degrees of freedom, these slight horizontal elastic properties can have undesired influence on the work results.

In this case the HAB horizontal air spring is used purely as an air bearing to reduce frictional effects; the required horizontal counter forces are generated by additional BiAir® elements. These additional BiAir® elements are fitted rotated 90° and replace the air hoses of the regular HAB™ air springs (see the Horizontal air springs section).

ADVANTAGES

- Best possible insulation properties specifically for applications with critical limit curves in the low frequency range.
- For applications with higher horizontal dynamics significantly higher counter forces can be realized by the additional BiAir® air springs than with standard AIS with 6 degrees of freedom.

ALS™

Active Isolation System

Noise and vibration insulation of research laboratories

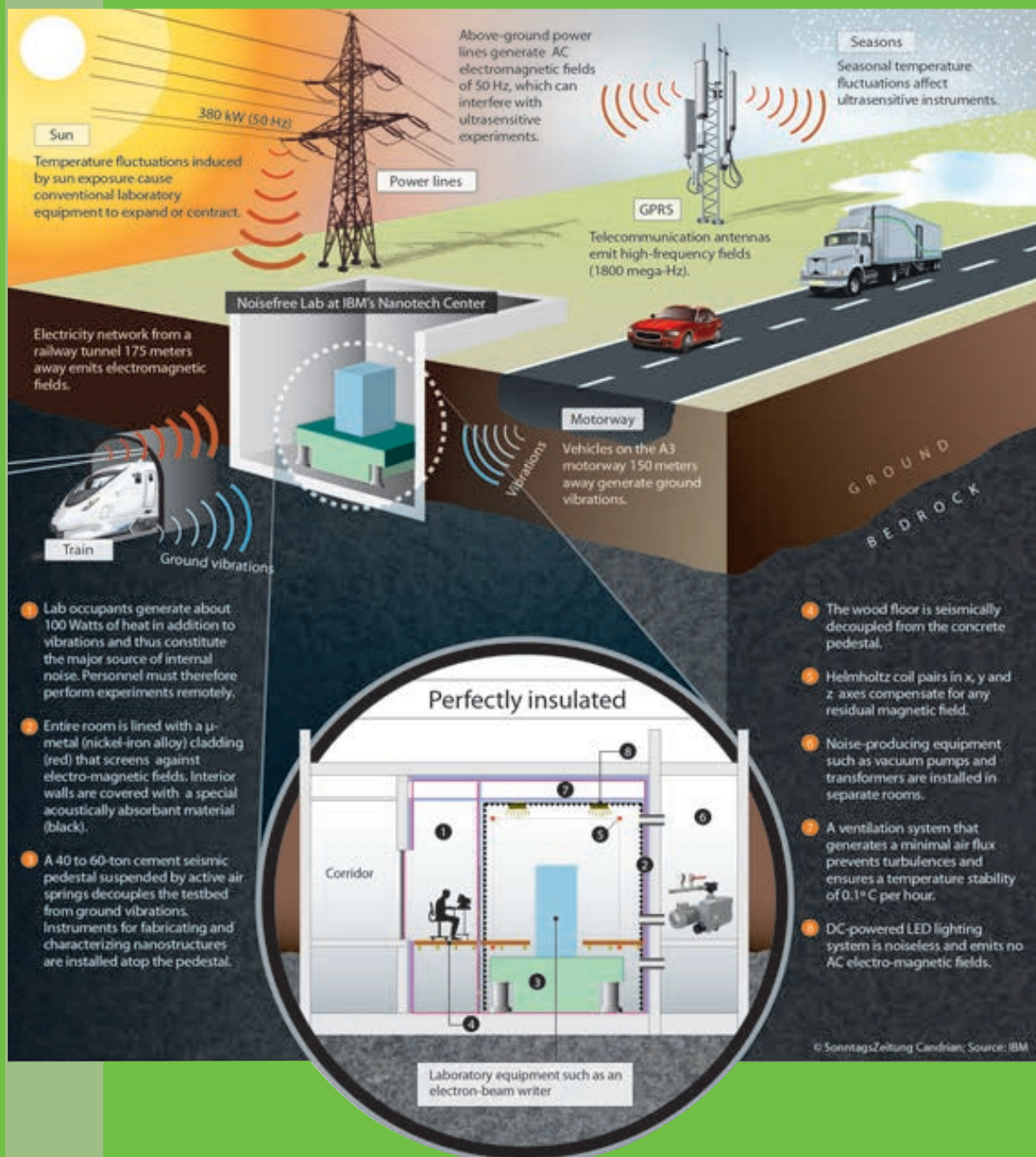

The illustration shows some of the most important measures for reducing external disturbing influences in the "noise-free labs" of Binnig and Rohrer Nanotechnology Centers of IBM and ETH in Zurich.

The manufacture and characterising of ever smaller components, down to structures comprising of only a few molecules or atoms, make the highest demands on vibration insulation to protect the vibration-sensitive systems.

In order to precisely perform sensitive experiments and measurements in the nanometre range (1 nanometre = one millionth of a millimetre), the external disturbing influences such as temperature, humidity and air pressure fluctuations, noise, electromagnetic fields or floor vibrations must be kept to an absolute minimum level.

Globally respected as a competent partner, Bilz have specialized in solutions such as laboratory insulation (foundation block or platform insulators) or the direct insulation of highly sensitive machines (installation of insulation systems in machinery/plant.)

Passive membrane air springs, air springs or active vibration insulator systems are used for high-quality vibration insulation.

Depending on the customer's wishes Bilz also creates the complete foundation block or platform design, or provides support in the design and constructive integration of the insulation in the machine.

We are very proud to have equipped the most modern research laboratories in the world with noise and vibration insulation, these include the "Precision laboratories MPI Stuttgart" or the "Noise-free lab" of the Binnig and Rohrer Nanotechnology Centre (IBM/ETH Zurich).

In the field of semiconductors renowned companies such as Applied Materials, Visotec and Zeiss are among our most esteemed customers.



Active vibration insulation AIS™ High Performance by Bilz, which suspends the glass fibre reinforced plastic armoured foundation block weighing 75 tons on air cushions.

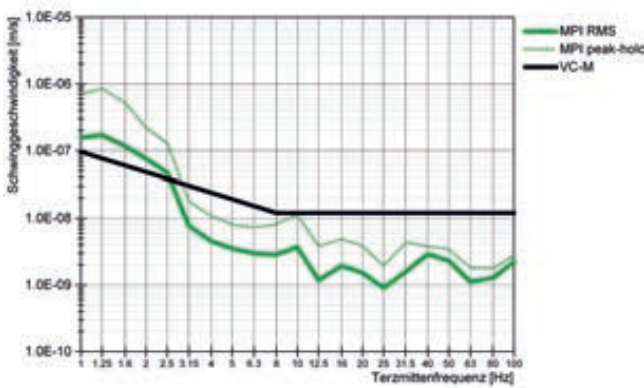

Result of vibration measurements on a foundation block insulated with Bilz membrane air springs.



Experimentation room with 4.2 m clear room height and acoustic insulation materials (supplied and installed by Bilz).

Source: Binnig and Rohrer Nanotechnology Center (IBM Research, Zurich).